

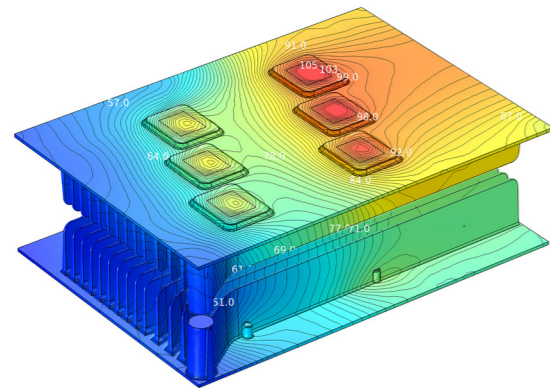

Fraunhofer
IFAM

Fraunhofer Institute for
Manufacturing Technology and
Advanced Materials IFAM
Branch Lab Dresden

Competence Center Energy and Thermal Management



Distribution of the temperature distribution in a heat sink

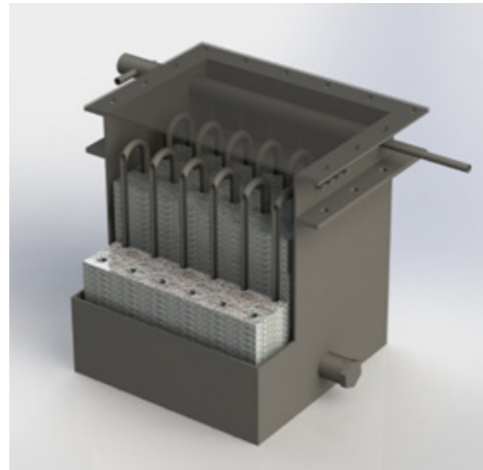

High-performance latent heat thermal energy storage based on a PCM fibre structure composite

Thermal characterisation

Depending on the material and the test conditions, the following methods, among others, are available for the determination of material characteristics, in particular also of complex material composites or phase change materials (PCM):

- Thermal conductivity: Stationary plate method, Hot Disk, flash method
- Specific heat capacity: Hot Disk, Differential Scanning Calorimetry (DSC)
- Latent heat & melting temperature: DSC, 3-layer calorimeter
- Other thermal analysis: DSC, Thermogravimetric Analysis (TGA)
- Thermal strain: Dilatometry (DLA)
- Cycling stability: Automated cycling apparatus, climatic chamber

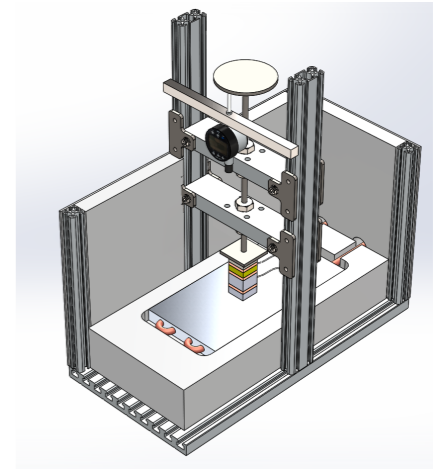

Plate apparatus for determining the thermal conductivity

The main fields of work of the Competence Center Energy and Thermal Management are the following

- efficient storage of thermal energy (heat - cold),
- optimisation of heat transfer processes (heating - cooling - evaporation - condensation),
- solving demanding tasks in the field of thermal management,
- the thermal design of energy and process engineering components.

Due to the direct link to the materials expertise of Fraunhofer IFAM Dresden, it is also possible to draw on a wide range of materials science know-how in order to make use of suitable materials for your application.

The employees of the competence centre have a broad and well-founded expertise from many years of professional experience in the experimental investigation and mathematical modelling of complex heat transfer, momentum and mass transfer processes.

Our services

- Studies and technology assessment
- Energy analysis of applications (balancing of energy and mass balance)
- Determination of material, heat transport and flow parameters
- Development of individual test rigs
- Thermal design of components
- Numerical simulation on a micro and macro scale
- Testing of components and systems in the laboratory

Fields of application

- Waste heat utilisation by application of thermal energy storage systems
- Thermal management of electrical components & batteries
- Components of the hydrogen economy
- High-performance evaporators
- Concepts and components for mould temperature control

Flow parameters are measured with the help of test rigs developed in-house. The following characteristic values, among others, can be determined:

- Heat transfer coefficient
- Pressure loss or pressure loss coefficient
- Permeability
- Viscosity

In addition, the evaluation of components and systems on a laboratory scale is possible for the following conditions:

- Heat transfer medium: Air/water/thermal oil
- Components: Thermal accumulators, heat exchangers, thermal management concepts, etc.
- Defined ambient conditions through a climate chamber

For characterisation, all relevant physical variables such as temperature, pressure or flow rate can be measured using suitable methods. In addition to the above-mentioned possibilities, the institute's material science characterisation options can be used directly if required. The measured data (e.g. material parameters) can also be used for numerical simulation within the scope of the possibilities available at the site.

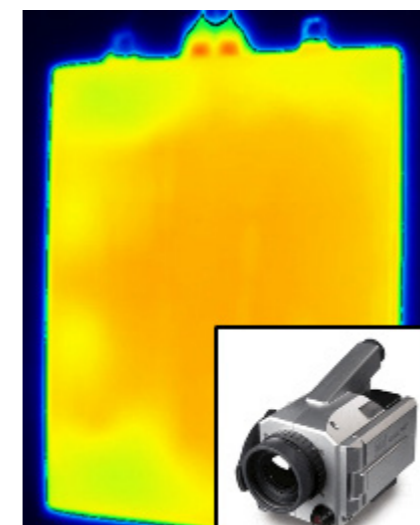

Thermographic image of a lithium-ion pouch cell

Numerical simulation

Various programmes are available for mathematical modelling and simulation, which are used depending on the specific application: COMSOL Multiphysics®, OpenFOAM®, OpenModelica®, MS Excel®. Each program offers individual advantages and disadvantages with regard to the processes to be modelled, model complexity, speed and accuracy.

The modelling is carried out depending on the specific application, depending on the necessary physical processes, e.g. heat transfer, mass transfer & flow (CFD) or mechanics. If required, these processes can also be simulated in combination to obtain all relevant results. The scale ranges from the micro to the macro level.

Advantages of simulation compared to experimental investigations are, among others, the reduction of the material effort for parameter variations especially, the limitation of the time effort and, thus, a fast feedback into the development as well as the possibility to identify optimal parameters. Particularly in the case of complex models, (partial) validation is recommended and can be covered with the help of the existing laboratory capacities for thermal characterisation.

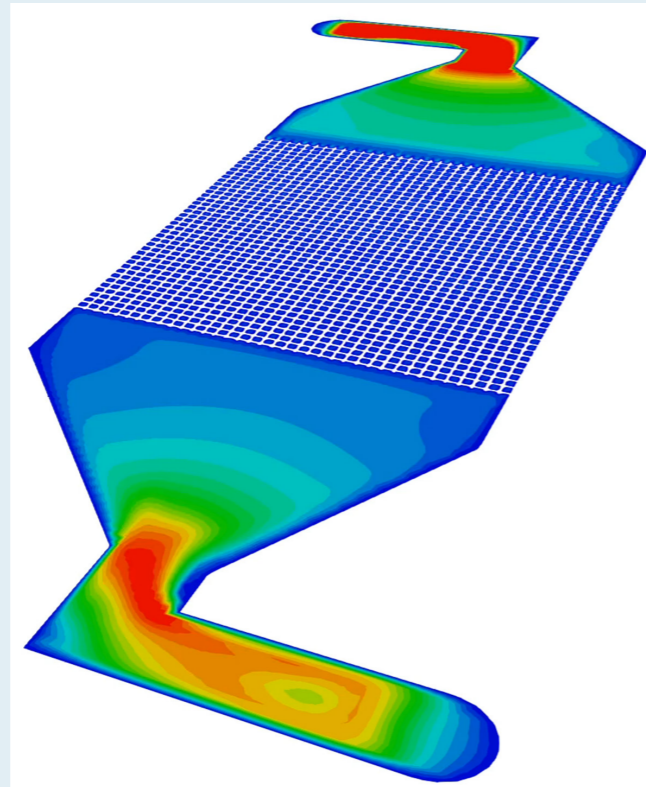

Flow field in an electrolytic cell for electrolysis

Component and test rig development

The methods and competences described for experimental and mathematical characterisation are also incorporated into the development projects carried out.

On the one hand, this can be the thermal design of components/concepts, e.g. for thermal energy storage, for the thermal management of electrical components (e.g. power electronics) or thermal processes.

On the other hand, depending on the measurement task, individual test rigs can be developed for your needs. The iterative process usually follows the following steps and is adapted to your individual requirements:

- Definition of the measurement task (what is to be measured)
- Which boundary conditions are to be observed
- Development of a design proposal
- Selection of commercially available components
- Design of individual components
- Procurement of all necessary components
- Assembly and commissioning or verification of successful operation

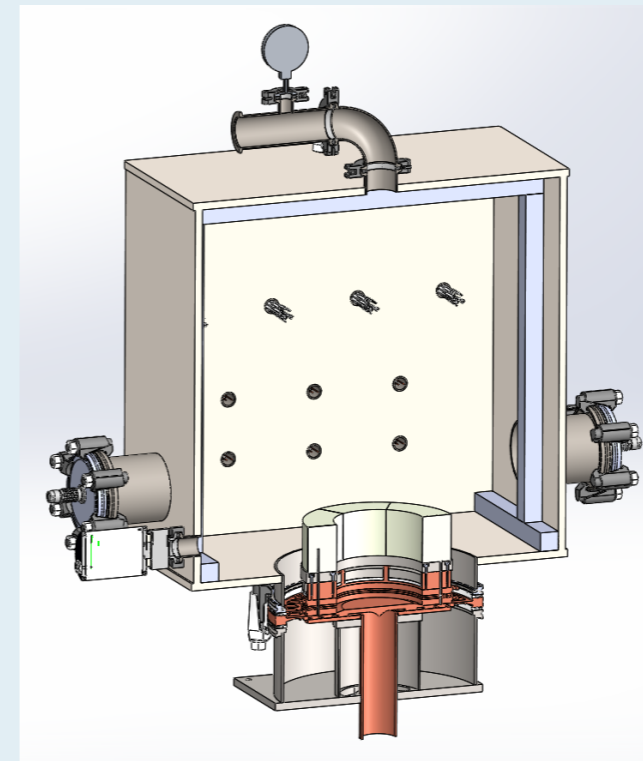

Test rig for thermal characterisation of a thermal interface for space applications

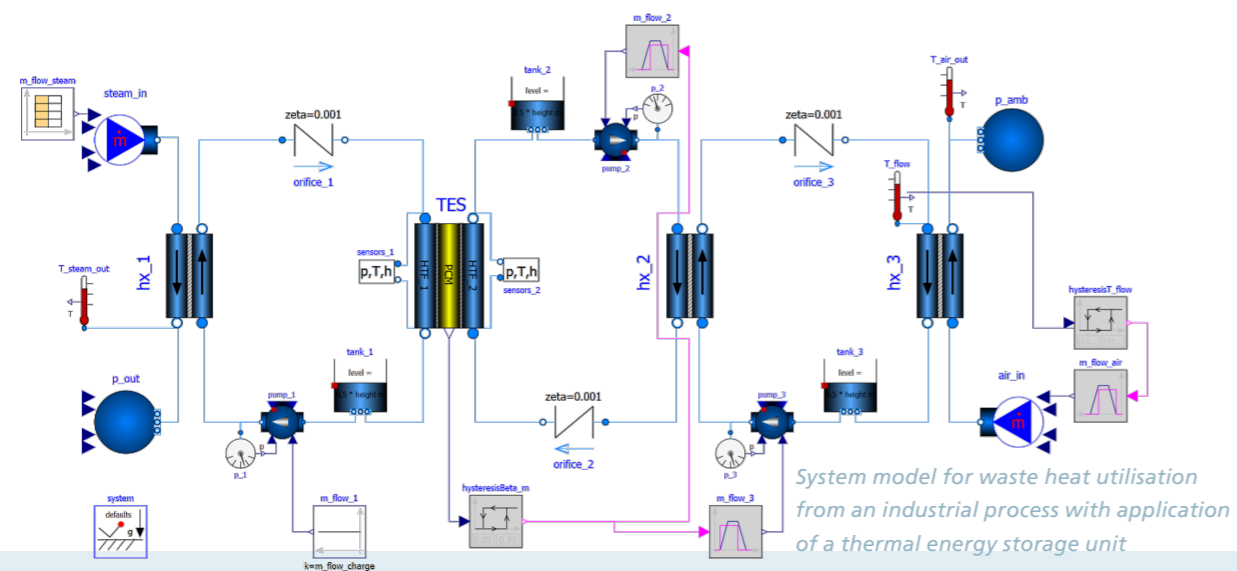

System model for waste heat utilisation from an industrial process with application of a thermal energy storage unit



Test rig for evaluating improved heat transfer on structured evaporator surfaces

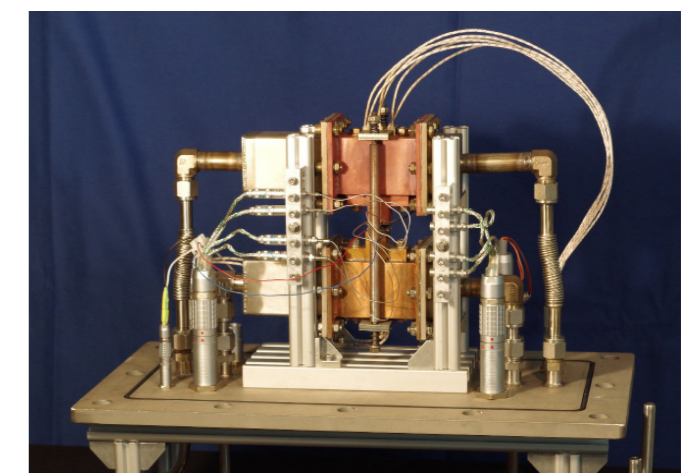

Test rig for characterising thermoelectric modules under cyclic temperature changes



Contact

Dr.-Ing. André Schlott
Head of Competence Center
Energy and Thermal Management
Phone +49 351 2537 435
Fax +49 351 2537 399
Mobile +49 1525 6608698
andre.schlott@ifam-dd.fraunhofer.de

Fraunhofer Institute for
Manufacturing Technology
and Advanced Materials IFAM
Branch Lab Dresden
Winterbergstrasse 28
01277 Dresden | Germany

www.ifam.fraunhofer.de/en/etm